ARDUINO-BASED ANTI-THEFT SYSTEM IN MOSQUE CHARITY BOX

Bagus Tri Syahputra

Universitas Panca Budi, Indonesia

bagustrisyahputra@gmail.com



*Corresponding Author

Article History:

Submitted: 03-06-2022

Accepted: 06-06-2022

Published: 13-06-2022

Keywords:

Sensor; Motion sensor; charity box security

Brilliance: Research of

Artificial Intelligence is licensed under a Creative Commons Attribution-NonCommercial 4.0 International (CC BY-NC 4.0).

ABSTRACT

The high level of criminal cases makes people have to be more vigilant. One of them is theft. Theft does not only occur in private areas such as homes, but often occurs in public locations, namely places of worship. There are many cases of theft of charity boxes at mosques or other places of worship. In this study, a security system was designed that was applied to the charity box. This tool is expected to reduce the rate of loss of donations in charity boxes. The charity box has an RFID sensor installed to unlock it and a motion sensor to detect movement if a thief tries to unlock the box.

INTRODUCTION

The application of security technology has developed rapidly, ranging from conventional methods to high-tech. In terms of security all methods require a key as validation. The validation key is called a password. Password is a sign of ownership to access a system. This password is in the form of numbers, letters, ID cards, fingerprints and others. this type of password still has many shortcomings, such as passwords that use numbers and letters are very vulnerable to errors in entering the password due to the combination of numbers & letters that are sometimes difficult to remember. As for passwords that use fingerprints, they will be slow to respond if the user's finger is injured or scratched. Seeing the lack of several types of passwords above, a system was created that uses ID cards as passwords. With this premise, many researchers use RFID as a security system, while their brains use a microcontroller. The use of RFID as a sensor is usually related to the field of Internet Of Things (IOT). Internet of Thing (IOT) is a field of science that discusses the digitization of security in robotics applications. Many previous studies have implemented security systems using RFID [1][2][3][4].

The charity box is one of the media for humans to do good by donating a small portion of the sustenance they get. It is often easy for us to find the existence of a charity box in a house of worship. The form of a charity box is usually a transparent box made of glass or iron board, although it is often made of wood. The money turned out to attract the attention of the thieves to take it. This crime is fairly high, as evidenced by the number of similar cases experienced by guards of places of worship. This is very disturbing to the community, especially before the big day of religious celebrations. In general, the existing charity boxes do not have a good security system and the use of padlocks seems impractical because they are easy to force open or break into.

Arduino is a microcontroller board based on the ATmega328. Arduino has 14 input/output pins of which 6 can be used as PWM outputs, 6 analog inputs, a 16 MHz crystal oscillator, a USB connection, a power jack, an ICSP header, and a reset button. Arduino is able to support microcontrollers; can be connected to a computer using a USB cable. Arduino has its own advantages compared to other microcontroller boards besides being open source, Arduino also has its own programming language in the form of C language. In addition, the Arduino board itself has a USB loader, making it easier for us when we program the microcontroller in Arduino. While on most other microcontroller boards that still require a separate loader circuit to enter the program when we program the microcontroller. The USB port is not only used as a loader when programming, but can also be used as a serial communication port. Arduino programming language is a C language that has simplified its programming language syntax making it easier for us to learn and explore microcontrollers [5]. Many previous studies have implemented the Arduino microcontroller as a controller [6][7][8].

The Arduino IDE is very advanced software written in Java. The Arduino IDE consists of:

1. Program editor, a window that allows users to write and edit programs in the Processing language.
2. Compiler, a module that converts program code (Processing language) into binary code. However a microcontroller will not be able to understand Processing language. What the microcontroller can understand is binary code. That's why a compiler is needed in this case.
3. Uploader, a module that loads binary code from a computer into memory on the Arduino board.

LITERATURE REVIEW

RFID

Radio Frequency Identification(RFID) is an identification method using a means called an RFID label or transponder to store and retrieve data remotely. An RFID tag or card is an object that can be attached or inserted into a product, animal or even human for the purpose of identification using radio waves. An RFID label contains information that is stored electronically and can be read up to several meters away. RFID reader systems do not require direct contact like barcode reader systems [9]. The appearance of RFID can be seen in Figure 1.



Figure 1. RFID

PIR sensor

The PIR sensor or also known as Passive Infra Red is a sensor used to detect the presence of infrared rays from an object shown in Figure 2. As the name implies, the PIR sensor is passive, which means that this sensor does not emit infrared light but can only receive infrared light. infrared radiation from outside. The PIR sensor can detect radiation from various objects and because all objects emit radiation energy, for example when a motion is detected from an infrared source with a certain temperature, namely humans trying to pass through another infrared source such as a wall, the sensor will compare the received infrared emission. every unit of time, so that if there is movement there will be a change in the readings on the sensor [10].



Figure 2. FOR Sensors

METHOD

In carrying out the research using several stages in completing the research method, namely:

1. Plan, In carrying out this design, a well-structured plan is needed in order to obtain objective and accurate results.
2. The analysis is carried out based on the method of making the circulation design. In addition, there are also references and materials for creating programs in Arduino Uno which are connected to RFID Sensors and PIR Sensors.

3. Design, an anti-theft charity box system. The design is divided into 2, namely hardware design and software design.
4. Implementation, Designing a charity box security prototype based on its performance level and frequency waves using the Arduino Uno microcontroller and the sensors used are RFID as a unlocking tool and motion detection PIR sensors, then Arduino Uno, as well as sensors and other components assembled into one, with additional miniature board box equipped with output, Led Buzzer, Relay and Solenoid lock in the process of anti-theft charity box security.

This security system is made using an Arduino microcontroller and is arranged in a prototype form. The block diagram can be seen in Figure 3. By utilizing the above materials, this system is expected to be useful for many people in the future. There is security that aims to increase the security of the charity box lock in places of worship with a flow of how to open the lock using a RIFD card and is equipped with a PIR Sensor to give sound notifications if there is an act of theft.

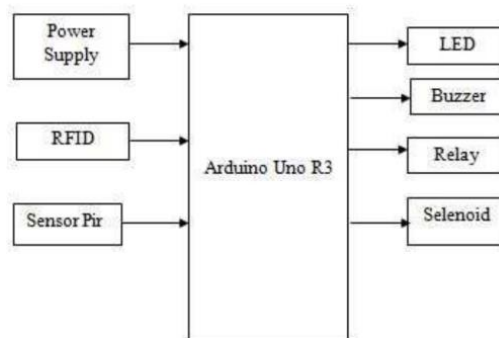

Figure 3. Block Diagram system

RESULT

Testing is done by making a charity box simulation prototype with the entire program loaded into the Arduino Uno, then given a power supply to the circuit that contains the sensor. When the buzzer is turned on for the first time, the buzzer will light up, if the card is attached to the RFID sensor, the buzzer will turn off and the green LED will light up. When opening the Solenoid lock the card is affixed to the RFID Sensor if the card code is correct then the Green Led will light up, the relay will turn on and open the Solenoid lock, if the card code affixed to the RFID Sensor is incorrect then the Red Led will light up and turn on the Buzzer, then the PIR Sensor is on if it reads the movement in front of it and will turn on the buzzer, when we want to turn off the buzzer the RFID card is attached to the RFID sensor then the Green Led will turn on and the buzzer will turn off.

Testing the RFID that has been connected to the Arduino circuit, when the RFID card is brought near to the sensor, the green Led will light up and open the Solenoid lock and disable the PIR sensor. If the RFID card is affixed again, the green Led will turn off, the Solenoid lock will close again and the PIR Sensor will be active again to detect movement. This process can be seen in Figure 4.

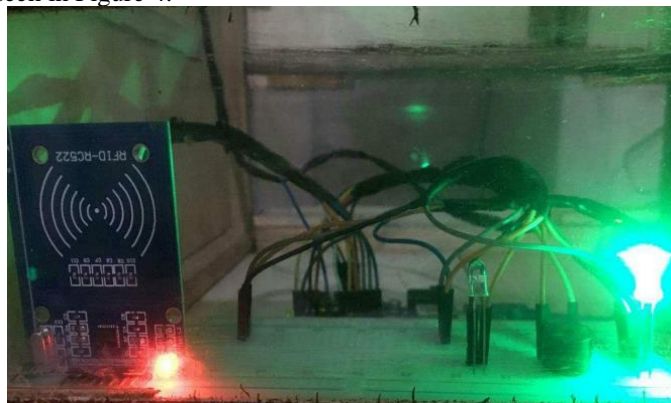

Figure 4. The LED lights up when the RFID card is brought near

DISCUSSION

Testing the doorlock solenoid connected to the 5 v relay serves to lock the charity box. This door lock Selenoid requires a supply voltage obtained from the adapter of 12v, the working system of this door lock solenoid is NC (Normally Close). The solenoid valve will be pulled if there is a voltage and vice versa the solenoid valve will be stretched if there is no voltage. The test can be seen in Figure 5.



Figure 5. Solenoid doorlock display

In testing this PIR sensor using a 5v voltage from Arduino and tested with human hand movements for movement that passes in front of the PIR Sensor, the work of this sensor is to detect human movement if motion is detected it will turn on the buzzer as a sign of danger movement that will threaten security charity box in figure 6.



Figure 6. PIR sensor testing

CONCLUSION

System hardware as an Arduino-based anti-theft charity box security system can be realized by combining several components and circuits, including: RFID, PIR Sensor, Solenoid lock, Relay, Led, Buzzer, each circuit is united by the Arduino uno microcontroller as a control. The arduino uno-based charity box security system can replace unlocking access that still uses a padlock or combination lock so that it is expected to be more effective using RFID.

REFERENCES

- [1]. Fatemeh B., Nemaï K., “A Cross Polar Orientation Insensitive Chipless RFID Tag”, IEEE RFID-TA, 2019
- [2]. Martina T.B., Gennaro G.B., Massimo M., “Field Focusing for Energy Harvesting Applications in Smart RFID Tag”, IEEE RFID-TA, 2019
- [3]. Massimo M., Demetrio I., Francesco G.D.C., “Reconfigurable UHF RFID tag with Sensing Capabilities”, IEEE RFID-TA, 2019
- [4]. Renata R.F.D, Hugo E.H., Luiz R.C., “Analysis of impact on the change of frequency band for RFID system in Brazil”, IEEE RFID-TA, 2013
- [5]. Steven F. Barrett, “Arduino II: Systems”, Book: Morgan&Claypool, 2021

-
- [6]. Ilham, D. N., Hardisal, H., Balkhaya, B., Candra, R. A., & Sipahutar, E. (2019). Heart Rate Monitoring and Stimulation with the Internet of Thing-Based (IoT) Alquran Recitation. *Sinkron*, 4(1), 221. <https://doi.org/10.33395/sinkron.v4i1.10392>
- [7]. Ilham, D. N., Satria, E., Anugreni, F., Candra, R. A., & Kusumo, H. N. R. A. (2021). Rain Monitoring System for Nutmeg Drying Based on Internet of Things. *Journal of Computer Networks, Architecture, and High-Performance Computing*, 3(1), 52–57. <https://doi.org/10.47709/cnahpc.v3i1.933>
- [8]. Nursila, N., Ilham, D. N., Yunan, A., Harahap, M. K., & Candra, R. A. (2021). Prototype of IoT-Based Fruit Alcohol Level Measurement Tool. *Brilliance: Research of Artificial Intelligence*, 1(1), 8–13. <https://doi.org/10.47709/brilliance.v1i1.1078>
- [9]. G. sriharsha Vardhan, Naveen S., Ashudeb D., “ QR-code Based Chipless RFID System for Unique Identification”, IEEE RFID-TA, 2016
- [10]. Arifin Bustanul, 2013. Aplikasi Sensor Passive Infrared (PIR) Untuk Pendeteksian Makhluk Hidup di Dalam Ruangan. Jurusan Teknik Elektro, Fakultas Teknologi Industri, Universitas Islam Sultan Agung Jl. Kaligawe Km.4 Semarang.