Android Based Door Security Design

Ruth Shyintia Rouli Marpaung

Universitas Panca Budi, Indonesia

ruthchyntia@gmail.com



***Corresponding Author**

Article History:

Submitted: 30-05-2022

Accepted: 01-06-2022

Published: 02-06-2022

Keywords:

Android; Door Security; Selenoid Door Lock

Brilliance: Research of Artificial Intelligence is licensed under a Creative Commons Attribution-NonCommercial 4.0 International (CC BY-NC 4.0).

ABSTRACT

Room insecurity such as cases of theft or fire can occur, especially in rooms that are not equipped with special security and guard systems. Based on this, it is necessary to develop a security system that can be accessed and monitored remotely and provides early warning of early indications of danger using smartphones. System development is carried out through the stages of making software and hardware. The hardware consists of Arduino Mega 2560 to manage the system, MySQL Database Server, CC3000 Wifi Shield as a communication device between Arduino and the server, Limit Switch to detect a forced push on the door, MQ-2 measuring gas leaks in the room, DHT-11 sensor to measure the room temperature, VC0706 camera to capture images in the door area. Android application as a system interface to change lock status and monitor room conditions. A warning notification of the danger indication of a gas leak is sent to the user's smartphone by displaying the value of the gas content. The warning message of a forced push on the door is equipped with a feature to display camera captures. The final result of this research is that a room security system has been successfully created where access to door locks and room monitoring can be done through an android application installed on a smartphone. The system can provide a hazard warning message well. The warning message of a forced push on the door is equipped with a feature to display camera captures. The final result of this research is that a room security system has been successfully created where access to door locks and room monitoring can be done through an android application installed on a smartphone. The system can provide a hazard warning message well. The warning message of a forced push on the door is equipped with a feature to display camera captures. The final result of this research is that a room security system has been successfully created where access to door locks and room monitoring can be done through an android application installed on a smartphone. The system can provide a hazard warning message well.

INTRODUCTION

Room insecurity such as cases of theft or fire can occur, especially in rooms that are not equipped with a security system and there is no special guard so that they can be accessed easily by unauthorized parties. The absence of data on access in and out of the room can also hamper investigations in the event of a theft.

Each room with limited access is usually equipped with a door to protect the various assets in it. The lock is one of the tools of the room security system which type can be in the form of a manual lock or an automatic lock with the help of electrical energy. Internet of Things (IoT) is a collection of things (things), in the form of physical devices (hardware/embedded systems) capable of exchanging information between information sources, service operators or other devices that may be connected to the system so that it can provide greater benefits. 4]. Embedded system devices perform computations for processing data from sensor inputs and operate within the internet infrastructure.

The door control and monitoring system to improve room security is research on the development of an IoT-based electronic lock system developed using Arduino Mega 2560 with Atmega16u2 CPU to manage the system, MySQL Database Server, CC3000 Wifi Shield as a communication device between Arduino and the server, Limit Switch used to detects a forced push on the door, MQ-2 for gas meter as an early indicator of a fire, DHT-11 sensor for measuring room temperature, VC0706 camera for capturing images in the door area and android application as a system interface to change lock status and monitor room conditions.

LITERATURE REVIEW

CC3000 Wifi Shield is a standalone wireless network module that combines internet connectivity into a simple project. The CC3000 module uses an SPI interface that allows the user to control the data flow and perform data transfers at a fairly high speed [6]. The display of the CC3000 Wifi Shield can be seen in Figure 1.



Figure 1. CC3000 Wifi Shield

Basically the solenoid door lock is an electromagnet which is commonly used as a door lock. Solenoid works after being given a voltage and has a Normal Close (NC) and Normal Open (NO) working system. To activate the 12 Volt DC solenoid, a 12 volt power supply and a relay are needed [7]. The type of solenoid door lock used in this study is a mini solenoid, with the following specifications:

- a. Input Voltage : 12 Volt DC
- b. Works at: 600 MA
- c. Unlock Time: 1 second – 10 seconds

The following is a display of the solenoid door lock as shown in Figure 2.



Figure 2. Solenoid Door Lock

METHOD

The design of the tool begins with making a block diagram to describe the overall system architecture design. The hardware consists of arduino mega 2560 to manage the system, MySQL database server, CC3000 wifi shield as a communication device between arduino and the server, limit switch to detect a forced push on the door, MQ-2 measures the presence of gas leaks in the room, DHT-11 sensor to measure the room temperature, VC0706 camera to capture images in the door area. Android application as a system interface to change lock status and monitor room conditions. A warning notification of an indication of the danger of a gas leak is sent to the user's smartphone by displaying the value of the gas content. The warning message of a forced push on the door is equipped with a feature to display camera captures.

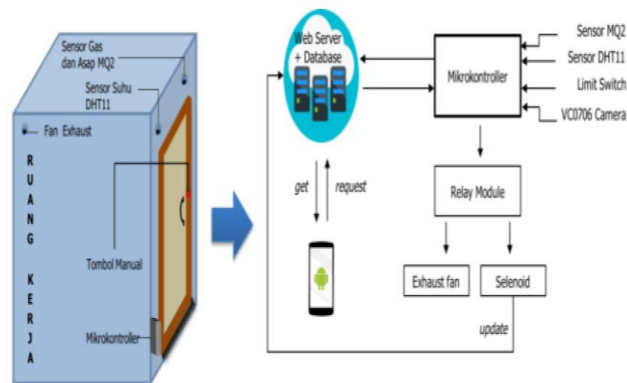

Figure 3. Overall Circuit Block Diagram

The microcontroller design scheme used to describe the connection scheme between Arduino and the DHT-11 sensor, MQ-2 sensor, VC0706 camera, Buzzer and Relay can be shown in Figure 4.

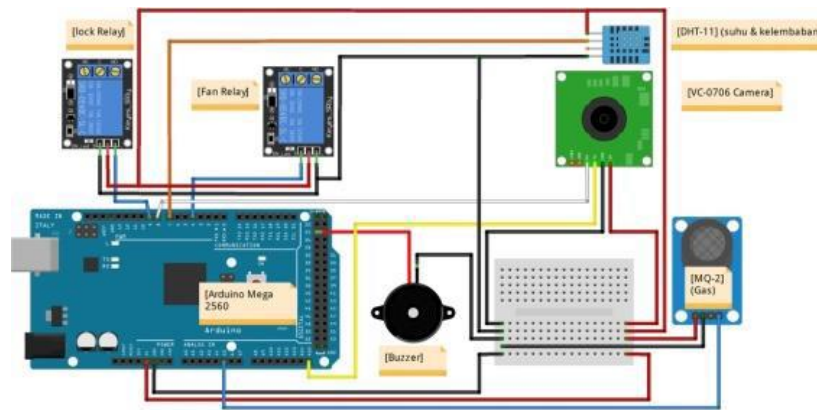

Figure 4. Microcontroller Design Schematic

RESULT

When normal conditions or do not detect a gas leak and forced push on the door, all danger indicators are OFF. This situation can be seen in Table 1.

Table 1. System test table under normal conditions

No	Component	Status	Door Condition	Kondiaii Buzzer	Exhaust Condition	Camera	Notifications
1	Lock Door	1/locked 0/unlocked	0/closed 1	OFF	OFF	OFF	OFF
2	Limit Switch	0/normal safe	open closed	OFF	OFF	OFF	OFF
3	Gas Sensor	(<40%)	-	OFF	OFF	OFF	OFF
4	Temperature Sensor	Highest 240C	-	OFF	OFF	OFF	OFF

When abnormal conditions are detected, namely a gas leak or forced push on the door/breakout, the reaction of the hazard indicators can be seen in Table 2.

Table 2. System test table under abnormal conditions

No	Component	Status	Door Condition	Kondiaai Buzzer	Exhaust Condition	Camera	Notifications
1	Lock Door	1/locked	0/open	ON	OFF	ON/capture	ON
2	Limit Switch	1/ not normal unsafe	open closed	ON	OFF	ON/capture	ON
3	Gas Sensor	(>40%)	-	ON	ON	OFF	ON
4	Temperature Sensor	Highest 360C	-	OFF	OFF	OFF	OFF

DISCUSSION

The lowest and highest temperature sensors are the values of the temperature measurement results by the DHT-11 sensor during the testing process. Based on observations that the increase in the temperature sensor does not provide a change in the status of the hazard indicator. This is in accordance with the limitation of the problem that the sensor in question is only limited to providing information related to room temperature. If the gas concentration in the room increases more than 40% then the exhaust will be ON, the danger indicator in the form of buzzer is ON, smartphone notification is ON. Exhaust and notifications will remain active until the indoor air condition is stable. If there is a forced push on the door, the actuator on the limit switch will detect the pressure and an electrical signal will change the status in the database from 0 (normal) to 1 (danger). This condition will trigger the buzzer to be ON, and the smartphone will receive a notification in the form of a crash indication. And the camera will capture the area in front of the door.

CONCLUSION

Based on the results of the design that has been done, it can be concluded that: Users can access and monitor door lock access through applications that have been installed on Android smartphones. The application system can provide warning messages or notifications to users when there is an indication of a gas leak danger or a forced push/break on the door, the exhaust fan can automatically turn on/on when an indication of a gas leak occurs and if the gas concentration is at a safe status then the exhaust fan will turn off. /off. The VC0706 camera can take pictures well when there is an indication of a door breaking.

REFERENCES

- [1] Siswanto, Gunawan PU, Windu G., 2, "Pengamanan Ruangan Dengan DFRDuino Uno R3, Sensor MC-38, PIR, Notifikasi SMS, Twitter", JURNAL RESTI (Rekayasa Sistem dan Teknologi Informasi) Vol. 2 No. 3 (2018), pp. 697 – 707, 2019.
- [2] Siswanto, Gata, Windu, dan Tanjung, Ronny, "Kendali Ruang Server Menggunakan Sensor Suhu DHT 22, Gerak PIR dengan Notifikasi Email" Sisfotek 2017, pp.134-142,2017.
- [3] Siswanto, Aditya A, Windu G., 2018. Kendali dan Monitoring Suhu Dan Ketinggian Air Aquarium Dengan Sensor DS18B20, HCSR04 dan Mikrokontroler ARDUINO UNO R3 Berbasis Web. Prosiding SNST ke-9 Tahun 2018.
- [4] Riki.R, Sutarti, Anharudin, "Rancang Bangun Kamera Pengawas Menggunakan Rasperry dengan Aplikasi Telegram Berbasis Internet of Things", Jurnal Prosisko, 8(1), hlm 18-32, 2021.
- [5] Seday,A. Yuniarti.E, & Sanjaya.E, "Rancang Bangun Home Automation Berbasis Rasperry Pi3 Model B dengan Interface Aplikasi Media Sosial Telegram Sebagai Kendali" Al-Fiziya, Jurnal of Materials Science, Geophysics, Instrumentation and Theoretical Phisics, 1(2), hlm.42-47, 2019.
- [6] Alfian D, Muhamad G.K, Reza.K, Yusuf.A., "Rancang Bangun Automatic Hand Washing Station Dengan

- Menggunakan Mikrokontroler Arduino Ino R3”, Jurnal Pendidikan, Matematika, dan Sains, 6(1), hlm. 175-186, 2021.
- [7] Ayu L., Oriza. C, “Prototype Sistem Pensortir Barang di Industri Menggunakan Loadcell berbasis Arduino Uno”, Jurnal Teknik Elektro dan Vokasional, 7(1), hlm. 27-36, 2021.
- [8] Renol.F, Hambali, “Perancangan Alat Pengukur Radar Gula dalam Darah Menggunakan Teknik Non-Invasive Berbasis Mikrokontroler Arduino Uno”, Jurnal Teknik Elektro dan Vokasional, 6(1), hlm 69-76, 2020.
- [9] Ariansyah, W., Ilham, D. N., Khairuman, K., & Candra, R. A. (2021). Opening Doors Using Internet Of Things (IoT) Based Face Recognition. *Brilliance: Research of Artificial Intelligence*, 1(2), 32–37. <https://doi.org/10.47709/brilliance.v1i2.1095>