Android Based Spark and Gas Leak Detection and Monitoring

Dwiny Meidelfi^{1)*}, Hanriyawan Adnan Moodutor²⁾, Fanni Sukma³⁾, Sandri Adnin⁴⁾

¹⁾²⁾³⁾Department of Information Technology, Politeknik Negeri Padang, Indonesia

¹⁾dwinymeidelfi@pnp.ac.id, ²⁾hamooduto@pnp.ac.id, ³⁾fannisukma@pnp.ac.id, ⁴⁾sandria@pnp.ac.id

ABSTRACT

LPG cylinder leakage is one of the causes of fires in the community. Preventing the fires, a fire and gas leak detection and monitoring device was made using a fire detector sensor and an Android-based MQ-6 to trigger it. Data collection techniques in the manufacture of gas and fire leak detection using a flame detector and the MQ-6 Sensor can be obtained from datasheets, journals, books and articles and several internet sites that support the manufacture of this device. In manufacturing gas leak detection devices or tools, there are two parts: the first to make hardware (hardware), then software (software). The result of this tool detection is that users can find out the level of LPG due to leaking of LPG cylinders and detect fire using Android notifications in real-time. The data is displayed in detail on the browser page. This study concludes that users are safer because there is a gas leak; the tool will detect LPG gas. A message will be displayed on the LCD screen, and a notification on Android, and the buzzer will automatically turn on. If there is a fire from detecting the gas leak, the fire detector will see the fire, which will send an alert to Android that there is a fire, and the buzzer will turn on.

Keywords: Sensor MQ-6; Android; NodeMCU ESP8266; Flame Detector; Microcontroller

INTRODUCTION

The Indonesian people who use Liquid Petroleum Gas (LPG) gas cylinders continue to increase yearly. This situation occurs because kerosene is challenging to obtain, and prices have soared to divert the use of kerosene to LPG. Users of LPG gas cylinders are not only in urban areas; even now, villagers have started to switch to using LPG gas. The most widely used LPG gas cylinders are those measuring 3 kg and 12 kg because the price is relatively low and easy to obtain in the community. Security is one of the essential aspects of a system or environment, whether residential, office, campus, rural or urban tourist attractions, shopping centres or other places, especially places prone to fire. Fires often occur due to human negligence caused by several factors such as leakage of LPG gas cylinders, cigarette butts being disposed of carelessly, and short circuits of electric current that cause fires and spread to other parts. Fire harms many parties morally and materially, and not a few also cause death. It is hoped that with this solution, the community will feel comfortable using LPG gas. And it is beneficial at home and in buildings to detect LPG gas, which can cause significant loss of property and life.

The tool designed is efficient and affordable to prevent losses from fires caused by LPG gas leaks by detecting gas leaks and fires. The detection system is an automatically integrated security system that provides information on the state of an event or condition that can be applied to housing, offices, campuses or agencies in need. This detection system uses an MQ-6 sensor and an Arduino Uno-based Flame Detector.

The MQ-6 Sensor is used to detect gas leaks. These gases include hydrogen gas, LPG, methane, carbon monoxide, alcohol, propane, and sensors. The fire sensor is a temperature sensor used to detect temperature. The advantage of using a fire sensor is that it has a linear temperature sensor whose calibration is direct, so it doesn't need a large constant voltage from the Celsius scale output.

Based on the discussion topic above, it is necessary to have a tool to detect and monitor sparks and gas leaks based on Android. Creating an innovation to minimize environmental damage that causes fires due to gas leaks.

LITERATURE REVIEW

Internet of Thing (IoT)

IoT is closely related to machine-to-machine (M2M) communications in manufacturing and electricity, oil and gas. Products built with M2M communication capabilities are often called intelligent or "smart" systems. (example: smart label, smart meter, smart grid sensor). (Yudhanto, 2007)

* Corresponding author



Arduino Uno

Arduino is a hardware and software platform that electronics enthusiasts can use to make prototypes of microcontroller-based controllers. The microcontroller is a micro-sized computer on a single IC chip (integrated circuit) consisting of a processor, memory, and programmable interface. It can be seen in Figure 1 Pin Diagram of Arduino Uno. (Santoso, 2015)

NodeMCU ESP8266

NodeMCU is a versatile wifi module equipped with GPIO, ADC, UART and PWM. NodeMCU ESP8266 functions as a client and controller of a sensor. NodeMCU ESP8266 will receive input from the Sensor and send data to the server and receive data from the server. Meanwhile, on the server-side, apart from displaying information, the server can send notifications to the user's e-mail. Applications are made on the server-side using the PHP programming language and MySQL database. (NodeMCU Documentation, 2016)

Sensor MQ-6

The MQ 6 sensor is a gas sensor suitable for detecting LPG (Liquefied Petroleum Gas) gas; it can detect LPG gas and includes gas consisting of LPG gas, namely propane and butane gas. This Sensor can detect gases at concentrations in the air between 200 to 10000 ppm. This Sensor has high sensitivity and a fast response time. The sensor output is an analogue resistance. The circuit of this Sensor is very simple; this Sensor requires to supply a voltage of 5 V, add a load resistance, and connect the output to the ADC. (Tryandana et al, 2015)

Flame Detector

A Flame Detector is an intelligent sensor system capable of detecting the position of the flame with high accuracy (up to a flame as small as candlelight). Flame Detector is only used to detect sparks or fires and does not detect heat. The working principle of a flame detector is that the fire can be detected by the presence of infrared and ultraviolet light spectrum. From there, a microprocessor in the flame detector will work to distinguish the light spectrum on the fire and the source. A flame sensor is used as a flame detector with a wavelength of 760 - 1100 nm of light. This Sensor works at a temperature of -25 0C - 85 0C, and this Sensor also has a detection angle of about 60 degrees, especially since it is very sensitive to the flame spectrum. For sensitivity, this Sensor has a Trimpot that can be rotated to adjust, and of course, the performance is very stable. (Thurbide, 2008)

Modul LCD I2C 1602 (Blue)

Inter-Integrated Circuit, or I2C, is a two-way serial communication standard using two channels designed to send and receive data. The I2C system consists of SCL (Serial Clock) and SDA (Serial Data) channels that carry data information between the I2C and the controller. Devices connected to the I2C Bus system can be operated as Enslaver and enslaved persons. Master is a device that initiates a data transfer on the I2C Bus by generating a Start signal, ending data transfer by generating a Stop signal, and developing a clock signal. The enslaved person is a master-addressed device.

Android

Android is a Linux-based mobile device operating system that includes an operating system, middleware and applications. Android has an open platform for developers to create applications. Initially, Google Inc. bought Android Inc., a newcomer making software for smartphones. The Open Handset Alliance was formed to develop Android, a consortium of 34 hardware, software and telecommunications companies. (Google Developer, 2015)

Amazon Web Service

Amazon Web Services (AWS) is a secure and trusted provider of cloud services; AWS provides computing power, database storage space, "content delivery network," and other functions that help businesses get ahead and run their applications well. (codepolitan.com, 2019)

Google Firebase

Firebase provides real-time database and backend services that Google currently owns. Firebase is a solution provided by Google to simplify Mobile Apps Developer projects. With Firebase, application developers can focus on developing applications without putting much effort into the backend business. (Firebase Features, 2019)

* Corresponding author



METHOD

The methodology used in this study with the following design scheme in Figure 1.

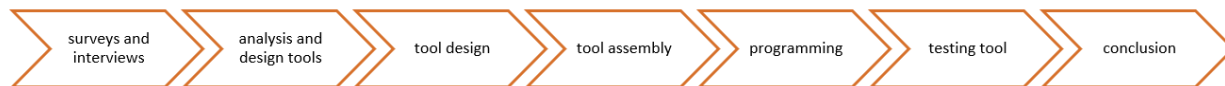

Fig. 1 Project design scheme

Survey and Interview Stage

At this stage, we are surveying the location and interviewing the surrounding community about the problem of frequent fires that often occur caused by LPG.

Analysis Stage

At this stage of the analysis, the process knows how the performance of the tool and its utilization so that the tool can be used and implemented by many people to solve a problem.

Design or Design Stage

After obtaining the solution to the problem or the tool's purpose, it is continued to the design or tool design stage. This stage can be described as preparing tools and materials or components used in the planned final project.

Assembling Stage

At this stage, the assembly process of the tools that have been designed is carried out. The assembly of Android-based spark and gas leak detection and monitoring tool is ready to be assembled and will proceed to the programming stage.

Programming Stage

At this stage, programming is carried out through software to relate the hardware to the software so that the tool can be run with the commands performed on the software.

Test Stage

At this stage, testing the detection and monitoring of sparks and gas leaks based on Android can know the performance of the tool and if there are still problems or the tool does not work as desired, at this stage immediately make repairs until the tool can be used as much as possible and various needs.

Conclusion

This Android-based spark and gas leak detection and monitoring tool can be used as a very simple and fast gas leak and spark detection tool to prevent fires. Through the activity of leaking gas and sparks, this tool will work and provide notifications sent directly to Android smartphone users.

RESULT

System Analysis

The system is an IoT-based embedded system consisting of several components: Arduino Uno, MQ-6 gas sensor, fire sensor, NodeMCU ESP8266, 16x2 LCD, Buzzer, Server and Android applications that are integrated. This is used to improve the monitoring system for sparks and gas leaks. This system serves to detect fires, gas leaks, air and smoke. The ability to interact with users by activating the Android application to get information on gas levels, LPG levels, CO levels, smoke levels, gas status, and fire status, then the Android application will issue a notification to fix it immediately.

System Design

In the design of this system is a prototype description of how the system will be made to make it easier to make the system.

* Corresponding author



Block Diagram System

The hardware used to make a prototype detection and monitoring of sparks and gas leaks based on Android uses the Arduino Uno microcontroller, NodeMCU, MQ-6 sensor, fire sensor, buzzer and LCD. NodeMCU is used to send data to the server with the help of web services. The servers used are Amazon Web Service (AWS) and Firebase. The components that have been assembled will be programmed on Arduino Uno with the C programming language so that they can be integrated or connected and find out the condition of LPG cylinder gas levels (data) and notifications on certain conditions. Figure 2 explains all the components integrated with each other, from Arduino Uno to Android.



Fig. 2 System Block Diagram

Electronic Circuit Design

An electronic circuit is a combination of components that show the ports or pins of the components that are used. The gas sensor uses 3 pins, namely vcc, ground and data, vcc is connected to the 5v Arduino Uno pin, the ground is connected to Arduino Uno ground, and the data pin is connected to the NodeMCU on pin A0. The fire sensor uses 3 pins, namely vcc, ground and data, vcc is connected to the 5v Arduino Uno pin, the ground is connected to Arduino Uno ground, and the data pin is connected to the NodeMCU on pin D4. The LCD uses 4 pins, namely VCC, Ground, SDA and SCL. The vcc pin is connected to the NodeMCU 3.3v power; the ground pin is connected to the NodeMCU ground pin, the SDA pin is connected to the D2 pin of the NodeMCU and the SCL pin is connected to the D1 pin of the NodeMCU. It is seen in Figure 3.

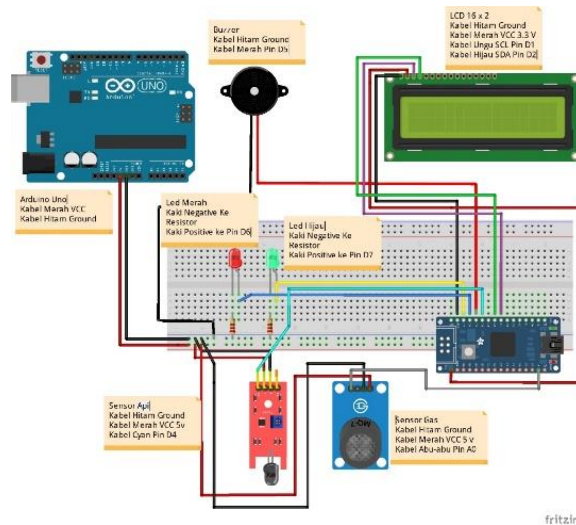

Fig. 3 Electronic Circuit Design

* Corresponding author



Arduino Uno System Flowchart

The MQ-6 Sensor and the Fire sensor will collect data; then, the data is processed. Check if the gas is >200. Then the program has been in ppm, and the fire is <1. If yes, the buzzer sounds and will send a message to the LCD to display the gas's danger. Otherwise, the MQ-6 Sensor will continue to collect data, repeating from the beginning as shown in Figure 4.

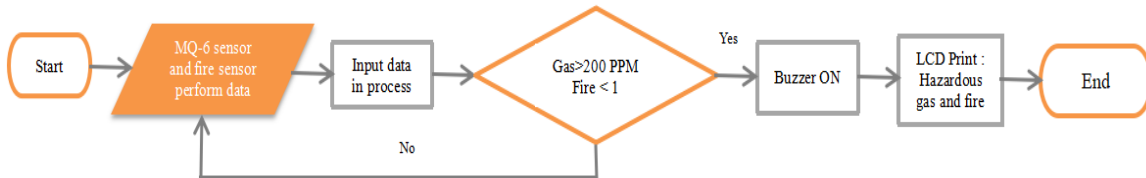

Fig. 4 Arduino Uno System Flowchart

Android Application System Flowchart

The Android application system flowchart is how the Android application system works. First displays the main display, then connects to the internet, if not connected then repeat by clicking to the internet, if connected then continue the process of retrieving data, data is recovered on the Firebase server. It can be seen in Figure 5.

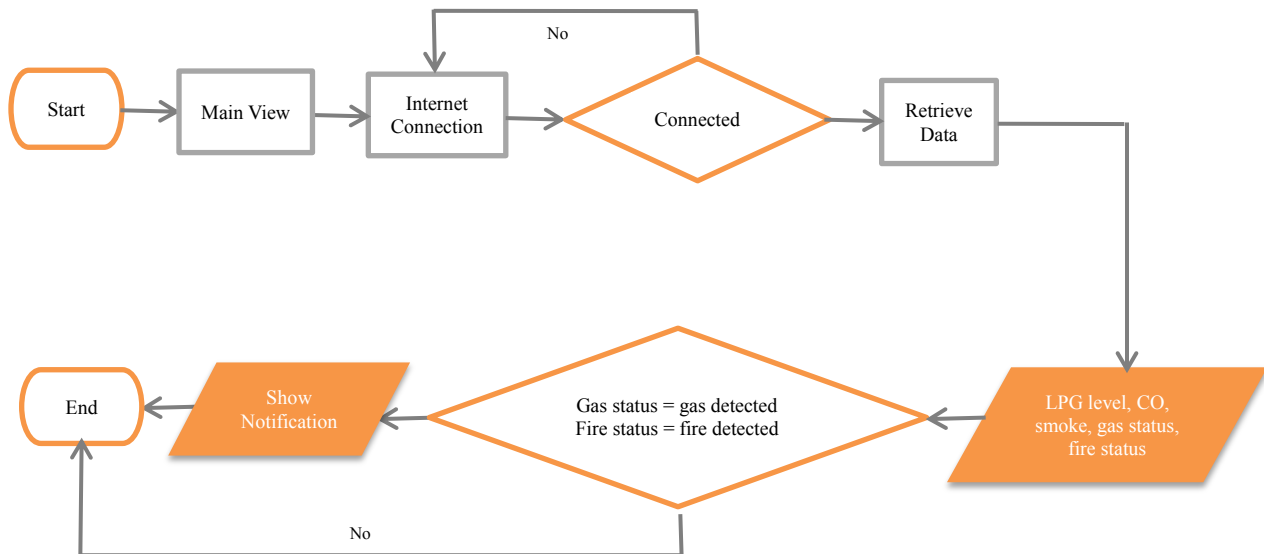

Fig. 5 Android Application System Flowchart

Determining whether or not notifications appear from the branching of gas status and fire status, the appearance of reports is caused if the gas status is detected and fire status is detected; the Android application will continue to loop the process from connecting to the internet until the notification appears or not.

Implementation and Testing

Test all components installed on Arduino Uno

Testing the Arduino Uno program is a test of the source code that has been created by combining all the necessary devices, including the MQ-6 gas sensor, fire sensor, buzzer, NodeMCU and others, to get the data that will be sent to the database. as well as the actions of all sensors. Arduino Uno testing can be seen on the serial monitor on the Arduino IDE.

* Corresponding author



Test on gas sensor MQ-6



Fig. 6 MQ-6 Gas Sensor Experiment

In Figure 6, the buzzer condition and the red led light are on at the gas level value (>200), the buzzer condition is off, and the green LED light is on at the gas level value (<200).

Test on fire sensor



Fig. 7 Fire Sensor Experiment

In Figure 7, the buzzer condition and the red led light is on when the fire sensor is rated(0), the buzzer is off, and the green LED is on when the fire sensor is valued (1).

Testing Data sent to PhpMyAdmin Database

Testing Data sent to PhpMyAdmin Database.

If possible, research results are discussed and compared with research results from the referenced articles.

- a. Data sent to PhpMyAdmin

* Corresponding author



Testing of data sent to the database can be seen in PhpMyAdmin. The following are the test results in Figure 8 below.

No	Gas	Lpg	Co	Smoke	status_gas	status_api	Date	Time
16	150	2	17	11	Gas Not Detected	Fire Not Detected	2019-08-09	23:48:26
17	139	4	27	3	Gas Not Detected	Fire Not Detected	2019-08-09	23:50:33
18	114	2	8	6	Gas Not Detected	Fire Not Detected	2019-08-09	23:50:52
19	118	0	4	3	Gas Not Detected	Fire Not Detected	2019-08-09	23:51:08
20	177	8	90	47	Gas Not Detected	Fire Not Detected	2019-08-09	23:51:45
21	206	117	3605	253	Gas Detected	Fire Not Detected	2019-08-09	23:53:37
22	190	36	427	125	Gas Not Detected	Fire Not Detected	2019-08-09	23:54:29
23	177	8	166	44	Gas Not Detected	Fire Not Detected	2019-08-09	23:54:45
24	190	11	123	52	Gas Not Detected	Fire Not Detected	2019-08-09	23:55:02
25	189	14	189	78	Gas Not Detected	Fire Not Detected	2019-08-09	23:55:19
26	162	5	46	22	Gas Not Detected	Fire Not Detected	2019-08-09	23:55:35
27	173	10	123	49	Gas Not Detected	Fire Not Detected	2019-08-09	23:55:53
28	177	337	1523	68	Gas Not Detected	Fire Not Detected	2019-08-09	23:56:10
29	226	8	90	33	Gas Detected	Fire Not Detected	2019-08-09	23:56:26
30	169	4	42	24	Gas Not Detected	Fire Not Detected	2019-08-09	23:56:42
31	8	0	0	0	Gas Not Detected	Fire Detected	2019-08-09	23:56:59
32	17	0	0	0	Gas Not Detected	Fire Not Detected	2019-08-09	23:57:16

Fig. 8 Data On PhpMyAdmin

Testing Data sent to Firebase Database

Testing Data sent to Firebase Database.

a. Data sent to Firebase.

Testing the data sent to the Firebase database can be seen in the test results in Figure 9 below.

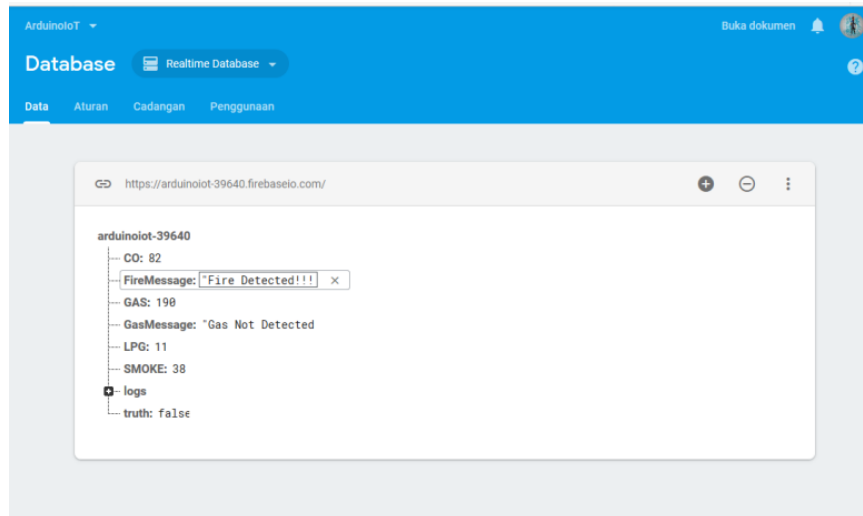

Fig. 9 Data Sent to Firebase

Android apps will use the Firebase database to get real-time data and updates.

1. Test Results on Android Applications

Test Results on Android Applications

* Corresponding author



a. Display of data results on the Android application

The results of the data display on the Android application will display data sourced from the Firebase database, as shown in Figure 10 below.

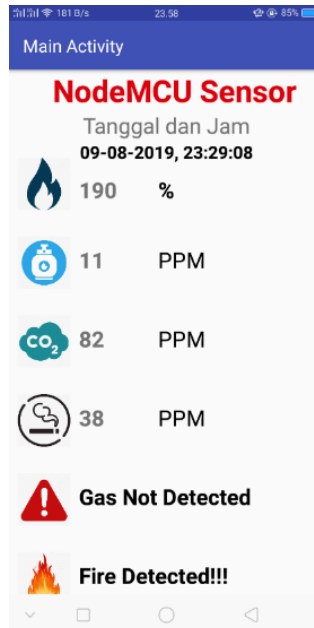

Fig. 10 Display Data on Android Applications

Gas leak notification display

When an LPG gas leak occurs, the Android application will display a notification and an alarm for a gas leak. It can be seen in Figure 11 below.

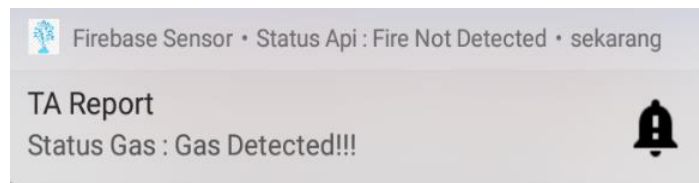

Fig. 11 Gas Leak Notification

a. Sparks notification display

When a spark occurs, the Android application will display a notification and an alarm for a spark. It can be seen in Figure 12 below.

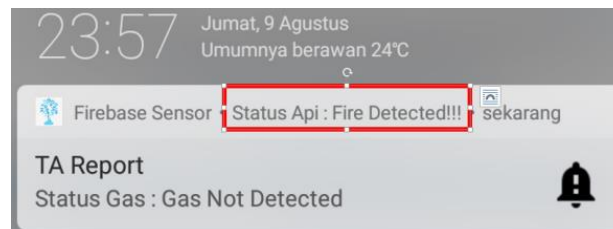

Fig. 12 Spark Notifications

* Corresponding author



DISCUSSIONS

Arduino Uno test displayed in browser web page with AWS Server

No	Gas Value	Lpg Value	Co Value	Smoke Value	Gas Status	Api Status	Date	Time
12	150	2	15	10	Gas Not Detected	Fire Not Detected	2019-08-09	23:47:19
13	148	6	56	27	Gas Not Detected	Fire Not Detected	2019-08-09	23:47:35
14	180	21	75	34	Gas Not Detected	Fire Not Detected	2019-08-09	23:47:52
15	181	10	189	66	Gas Not Detected	Fire Not Detected	2019-08-09	23:48:08
16	150	2	17	11	Gas Not Detected	Fire Not Detected	2019-08-09	23:48:26
17	139	4	27	3	Gas Not Detected	Fire Not Detected	2019-08-09	23:50:33
18	114	2	8	6	Gas Not Detected	Fire Not Detected	2019-08-09	23:50:52
19	118	0	4	3	Gas Not Detected	Fire Not Detected	2019-08-09	23:51:08
20	177	8	90	47	Gas Not Detected	Fire Not Detected	2019-08-09	23:51:45
21	206	117	3605	253	Gas Detected	Fire Not Detected	2019-08-09	23:53:37
22	190	36	427	125	Gas Not Detected	Fire Not Detected	2019-08-09	23:54:29
23	177	8	166	44	Gas Not Detected	Fire Not Detected	2019-08-09	23:54:45
24	190	11	123	52	Gas Not Detected	Fire Not Detected	2019-08-09	23:55:02
25	189	14	189	78	Gas Not Detected	Fire Not Detected	2019-08-09	23:55:19
26	162	5	46	22	Gas Not Detected	Fire Not Detected	2019-08-09	23:55:35
27	173	10	123	49	Gas Not Detected	Fire Not Detected	2019-08-09	23:55:53
28	177	337	1523	68	Gas Not Detected	Fire Not Detected	2019-08-09	23:56:10
29	226	8	90	33	Gas Detected	Fire Not Detected	2019-08-09	23:56:26
30	169	4	42	24	Gas Not Detected	Fire Not Detected	2019-08-09	23:56:42
31	8	0	0	0	Gas Not Detected	Fire Detected	2019-08-09	23:56:59
32	17	0	0	0	Gas Not Detected	Fire Not Detected	2019-08-09	23:57:16
33	10	0	0	0	Gas Not Detected	Fire Not Detected	2019-08-09	23:57:33
34	27	0	0	0	Gas Not Detected	Fire Not Detected	2019-08-09	23:57:51
35	48	0	0	0	Gas Not Detected	Fire Not Detected	2019-08-09	23:58:08

Fig. 13 Arduino Uno Test Results

CONCLUSION

With this gas leak detection system, the MQ6 Sensor can detect a gas leak and send data directly to the LCD screen, web browser and Android. This flame detector can catch fire and send data directly to the LCD, web browser and Android. If there is a spark and gas leak, the buzzer alarm will sound and display a notification on Android to warn of a fire and gas leak. After all the systems are running, it makes it easier for us to detect fire and gas leaks. Using this detector can even reduce the level of loss for the community because the danger of fire can be detected early.

REFERENCES

- Alamsyah, R. C., & Chaniago, M.B. (2019). Design of Cloud Computing Based Gas Detection System using NodeMCU ESP8266 Microcontroller. *IJID (International Journal on Informatics for Development)*, 8(2), 69-73.
- Aris, M. (2012). Liquid Crystal Display 16x2 (LCD).
- Amnur, H., Defni, dkk. (2015). Monitoring Kebocoran Pada Pipa Menggunakan SMS Gateway. *JPR (Jurnal Ilmiah Poli Rekayasa)*, 10(2).
- Hutagalung, D.D. (2018). Rancang bangun alat pendeteksi kebocoran gas dan api dengan menggunakan sensor MQ2 dan flame detector. *Jurnal Rekayasa Informatika*, 7(2).
- Nurnaningsih, D. (2018). Pendeteksi kebocoran tabung LPG melalui SMS gateway menggunakan sensor MQ-2 berbasis Arduino Uno. *Jurnal Teknik Informatika*, 11(2), 122-126.
- Gusdevi, H., Setya P., dkk. (2020). Prototype of LPG leakage detector using flame sensor and MQ-2 sensor. *Computer Science and Information Technologies*, 1(1), 32-38.
- Lapshina, P. D., Kurilova, S. P., & Belitsky, A. A. (2019). Development of an Arduinobased CO2 Monitoring Device. *In 2019 IEEE Conference of Russian Young Researchers in Electrical and Electronic Engineering (EIConRus)*, pp. 595-597.
- Mahmood, S.N., Asnor J.I., & Salam T.H. (2019). GSM based gas leak monitoring system. *Periodic of Engineering and Natural Sciences*, 7(2), 670-678.
- Mifza F.P., Awang H.K., dan Zainal A. (2017). Rancang Bangun Alat Pendeteksi Kebocoran Gas Lpg Dengan Sensor Mq-6 Berbasis Mikrokontroler Melalui Smartphone Android Sebagai Media Informasi. *Jurnal Informatika Mulawarman*. 12(1).

* Corresponding author



-
- Putra, M.F., Kridalaksana A.H., & Arifin, Z. (2017). Rancang bangun alat pendeteksi kebocoran gas LPG dengan sensor MQ-6 berbasis mikrokontroler melalui smartphone android sebagai media informasi. *Jurnal Informatika Mulawarman*, 12(1), 1-6.
- Triyandana, M.I., Muid, A., & Rismawa, T. (2015). Pendeteksi Gas LPG Dan Metana Dengan Sensor TGS 2610 Dan Sensor TGS 2611 Berbasis Mikrokontroler ATMEGA328P. *Jurnal Hasil Riset*.
- Nasution, T.H., dkk. (2017). Electrical appliances control prototype by using GSM module and Arduino. (*ICIEA Industrial Engineering and Applications*).
- Hidayatullah, R., Muchtar, H. (2015). Robot Pendeteksi Kebocoran Gas Menggunakan Mikrokontroler Atmega 328 Dan Sensor Gas MQ6. *Elektrum*, 11(2).
- Rahmawati, Evi, & Aeni, F. (2019). Arduino-Base Leak Detection System. (ITSMART) *Jurnal Ilmial Teknologi dan Informasi*, 8(2), 83-85.
- Rimbawati, H., Setiadi, R., Ananda, & Ardiansyah, M. (2019). Perancangan Alat Pendeteksi Kebocoran Tabung Gas LPG Dengan Menggunakan Sensor MQ-6 Untuk Mengatasi Bahaya Kebakaran. *Journal Of Electrical Technology*, 4(2), 53-58.
- Santoso, H. (2015). Panduan Praktis Arduino Untuk Pemula.
- Singh A., Verma, M., & Sahu, L. (2018). Detection of liquefied petroleum gas using sensor through arduino uno microcontroller. *International Research Journal of Engineering and Technology*, 5(4), 2101-2104.
- Sholeh, A.T., dkk. (2013). Mengamankan Skrip Pada Bahasa Pemograman PHP dengan Menggunakan Kriptografi BASE64.
- Thurbide, K. B. (2008). Flame detector.
- Yudhanto, Y. (2007). Apa Itu IoT (Internet Of Things).
- Putra, M.F., Kridalaksana, A.H., & Arifin, Z. (2017). Rancang Bangun Alat Pendeteksi Kebocoran Gas Lpg Dengan Sensor Mq-6 Berbasis Mikrokontroler Melalui Smartphone Android Sebagai Media Informasi. *Jurnal Informatika Mulawarman*. 12(1).

* Corresponding author



This is an Creative Commons License This work is licensed under a Creative Commons Attribution-ShareAlike 4.0 International (CC BY-SA 4.0).